

DE MONTAGEANLEITUNG
Slipwagen

EN INSTALLATION MANUAL
Boat Trolley

TR350-XXL / TR350-XXL-LU

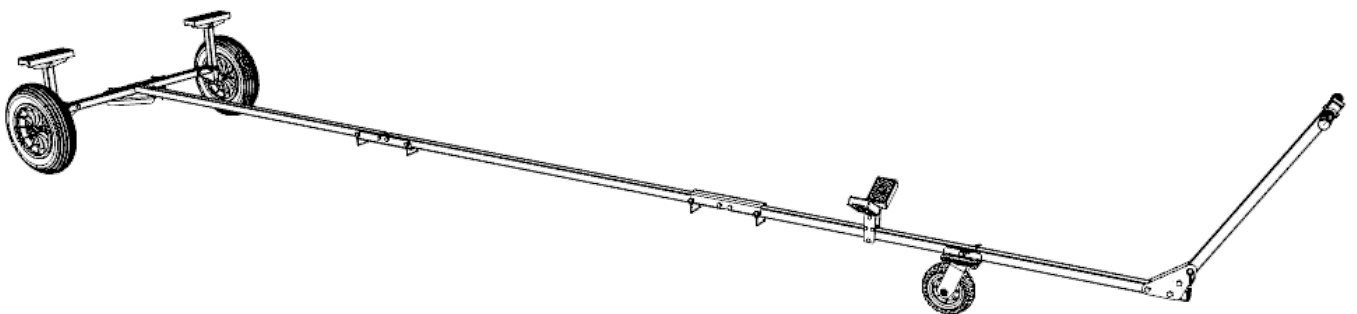
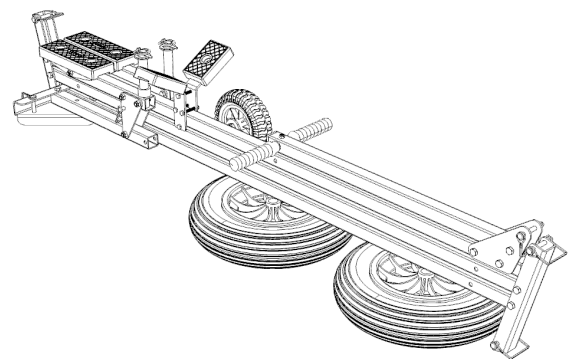

Inhalt / Contents

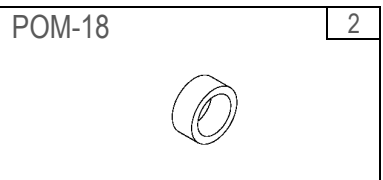
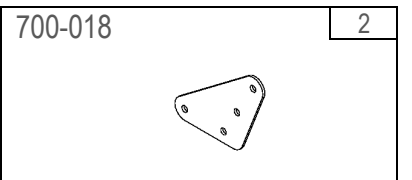
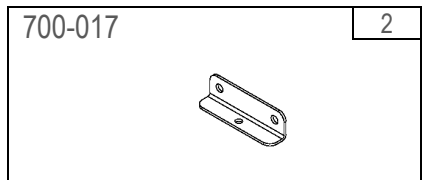
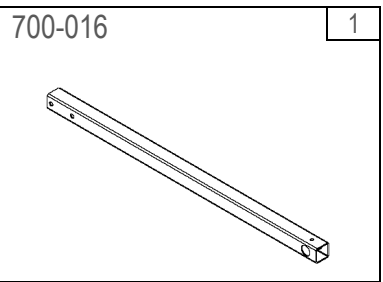
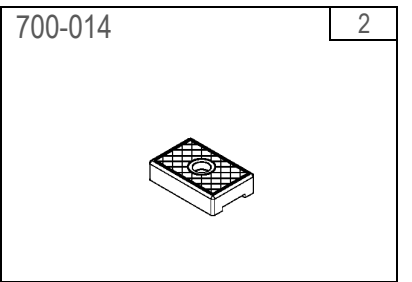
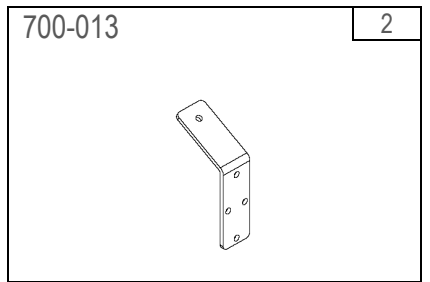
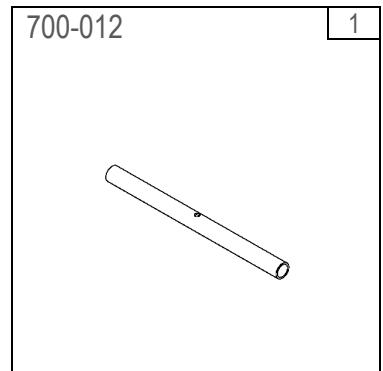
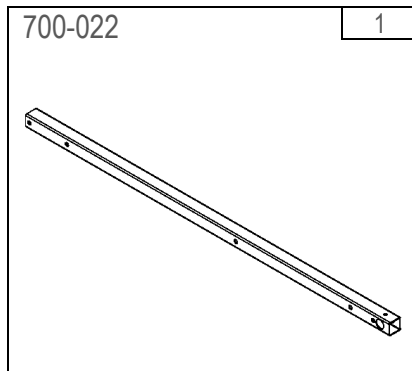
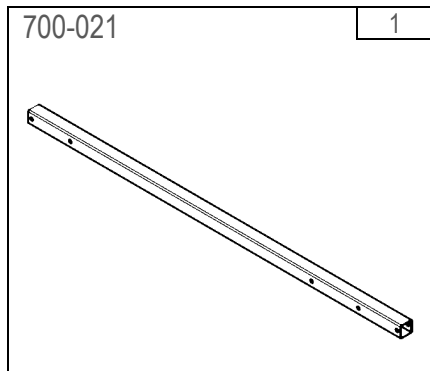
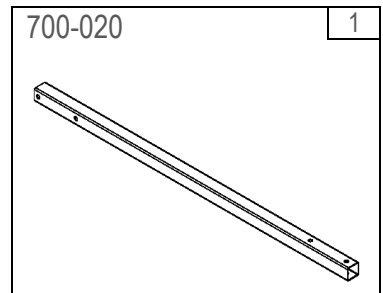
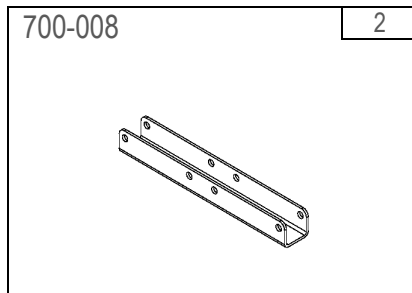
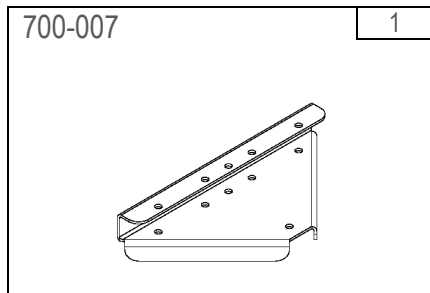
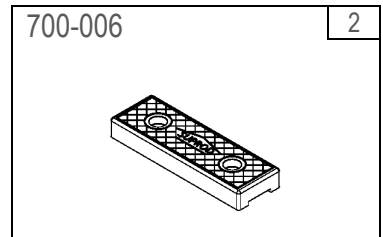
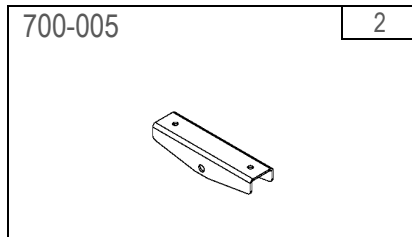
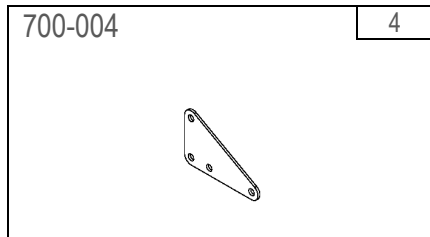
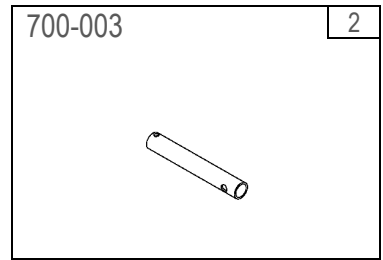
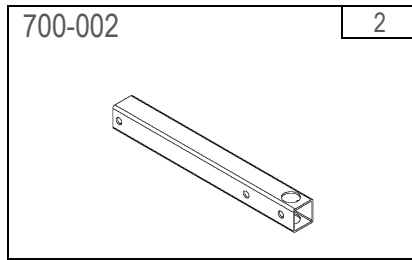
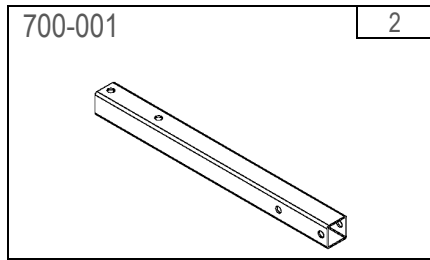

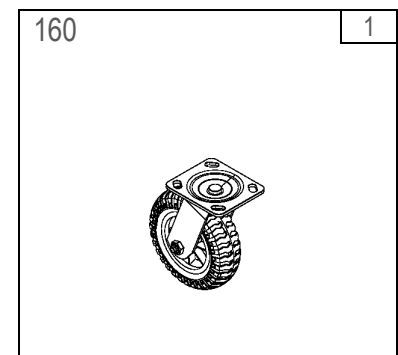
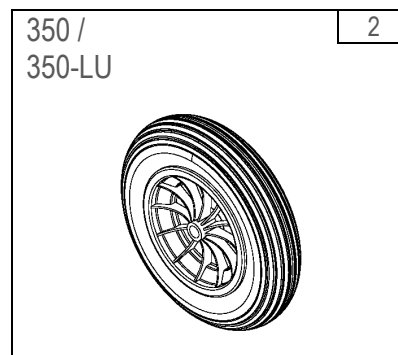
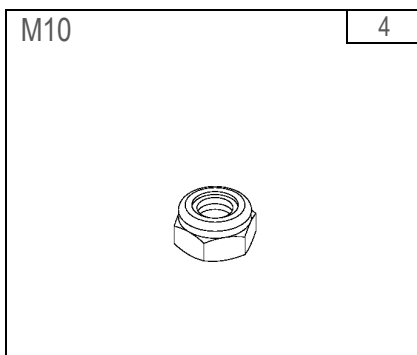
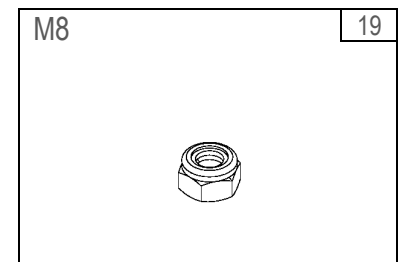
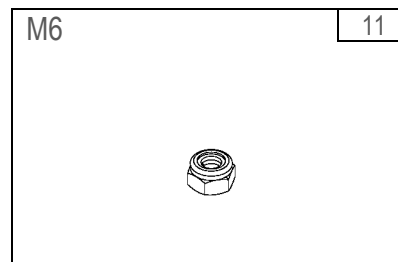
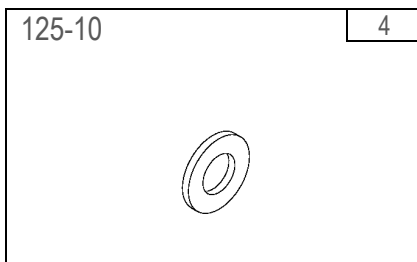
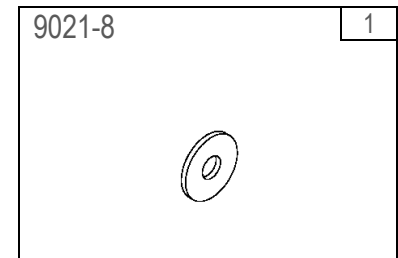
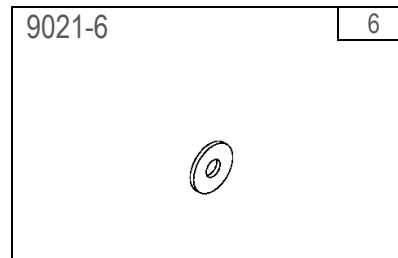
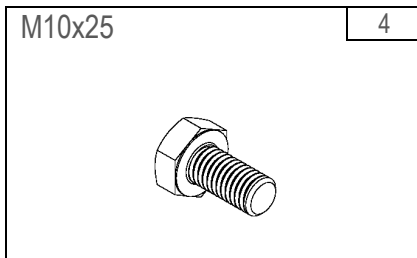
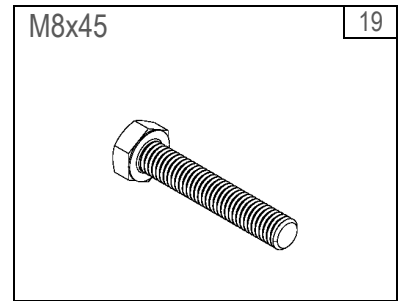
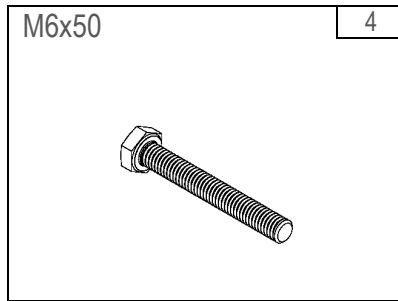
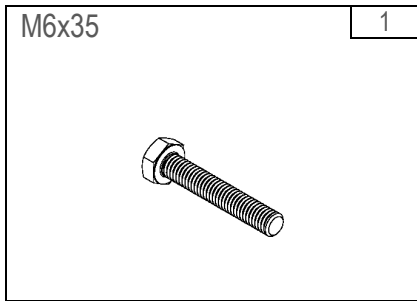
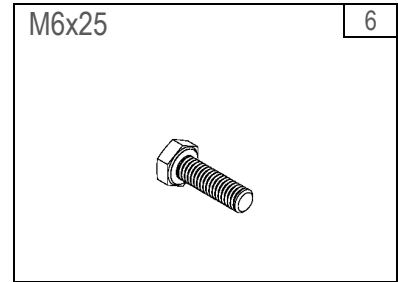
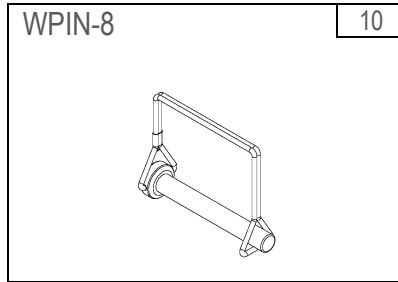
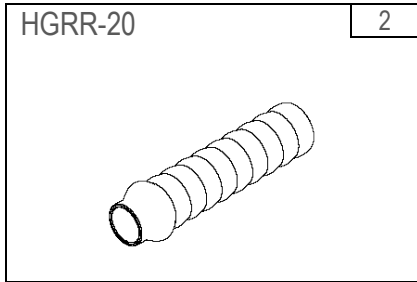
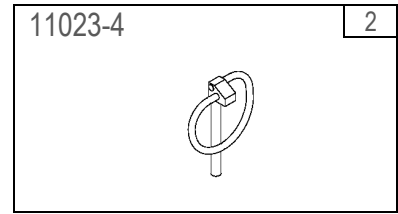
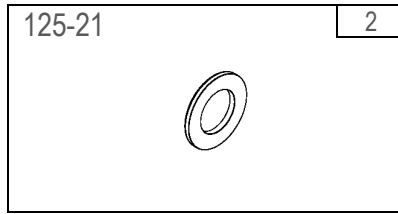
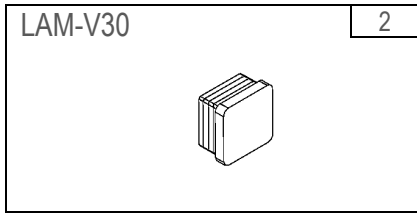

Montageschritte / Installation Steps

1

2 x

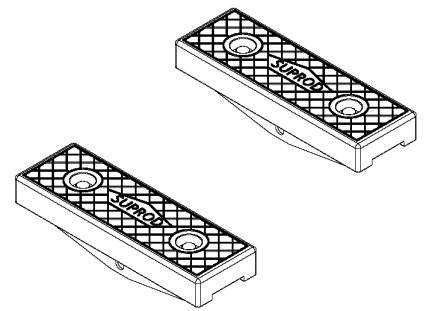
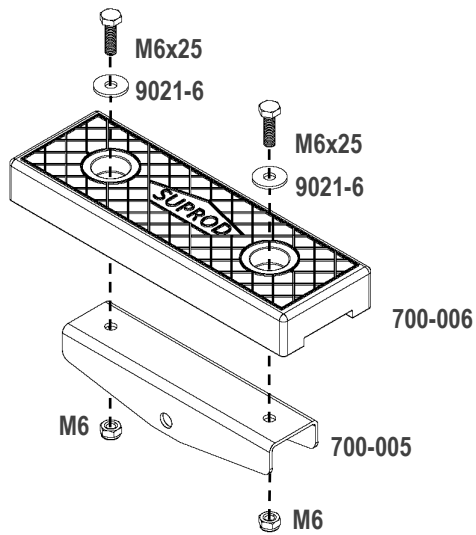

2

2 x

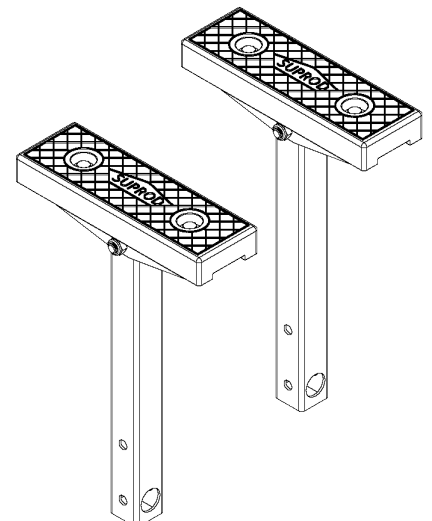
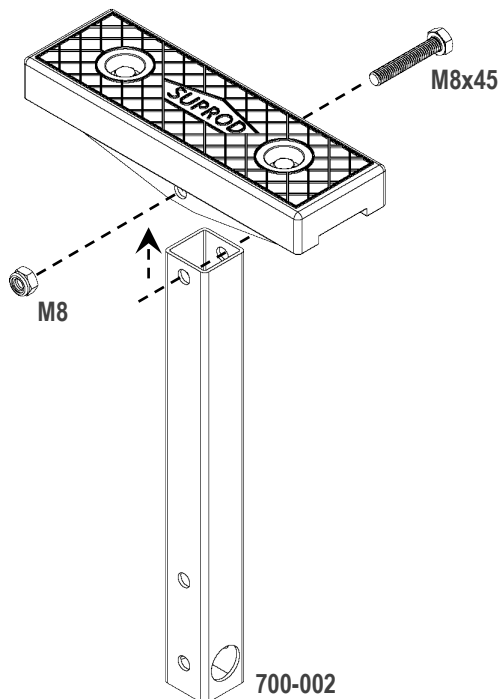

3

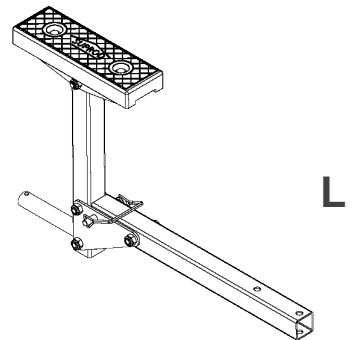
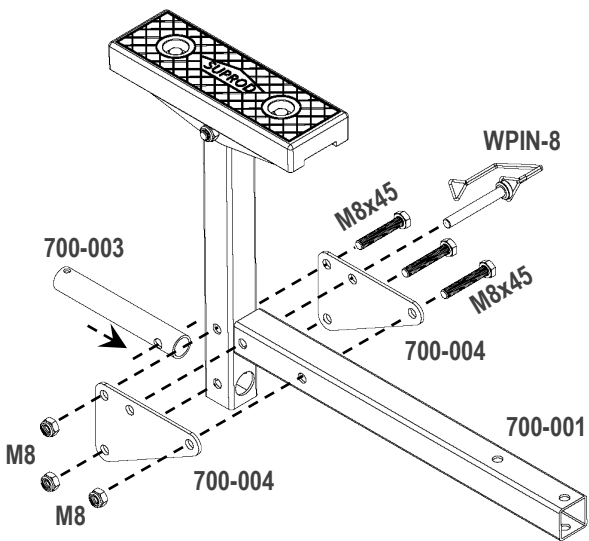
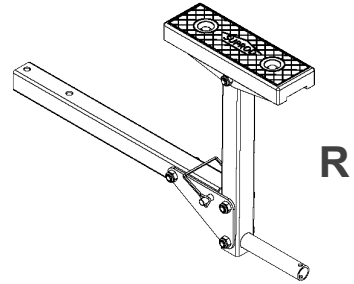
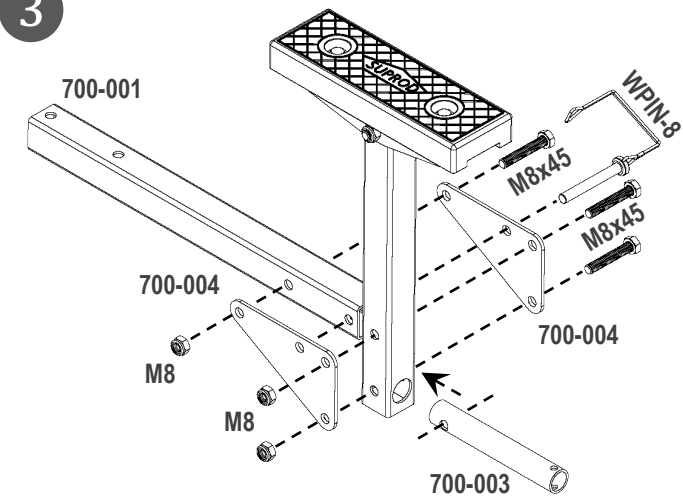

4

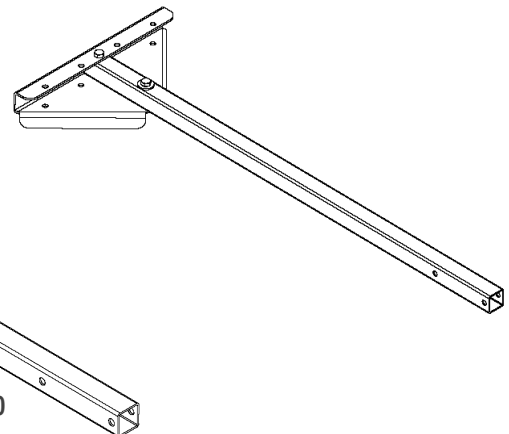
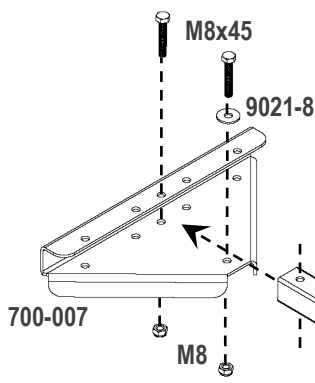

5

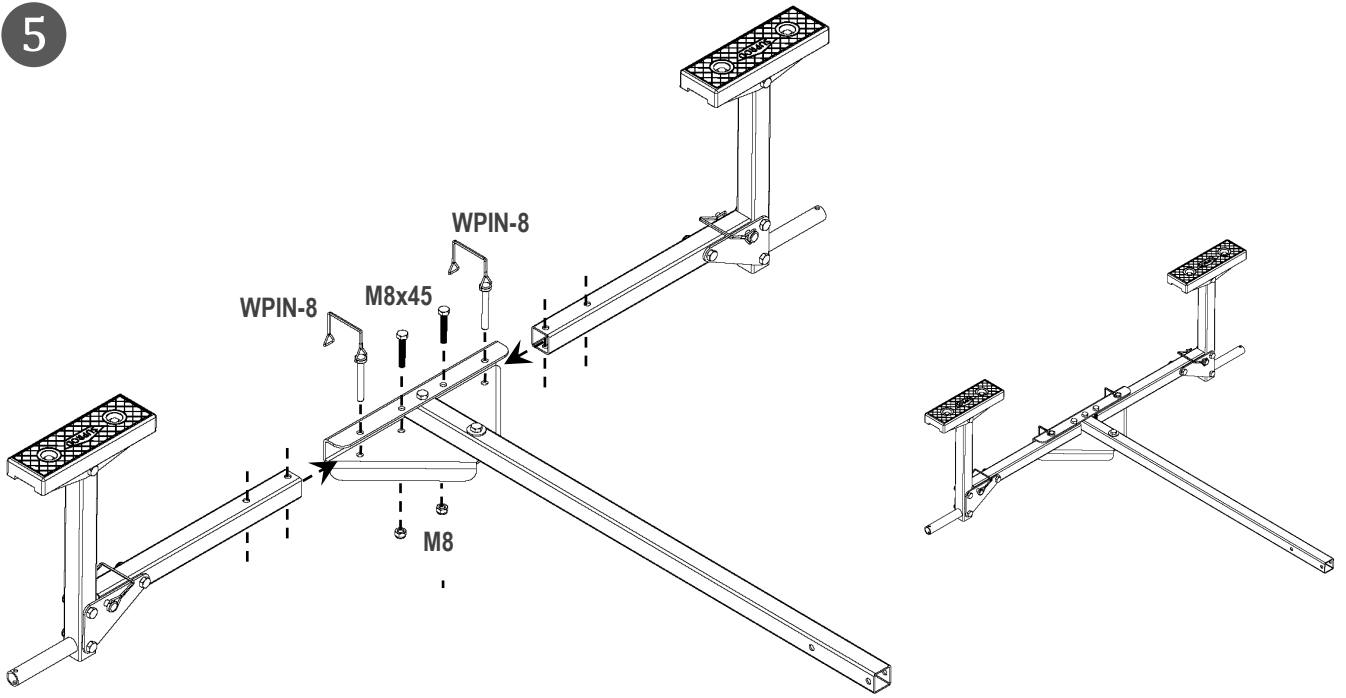

6

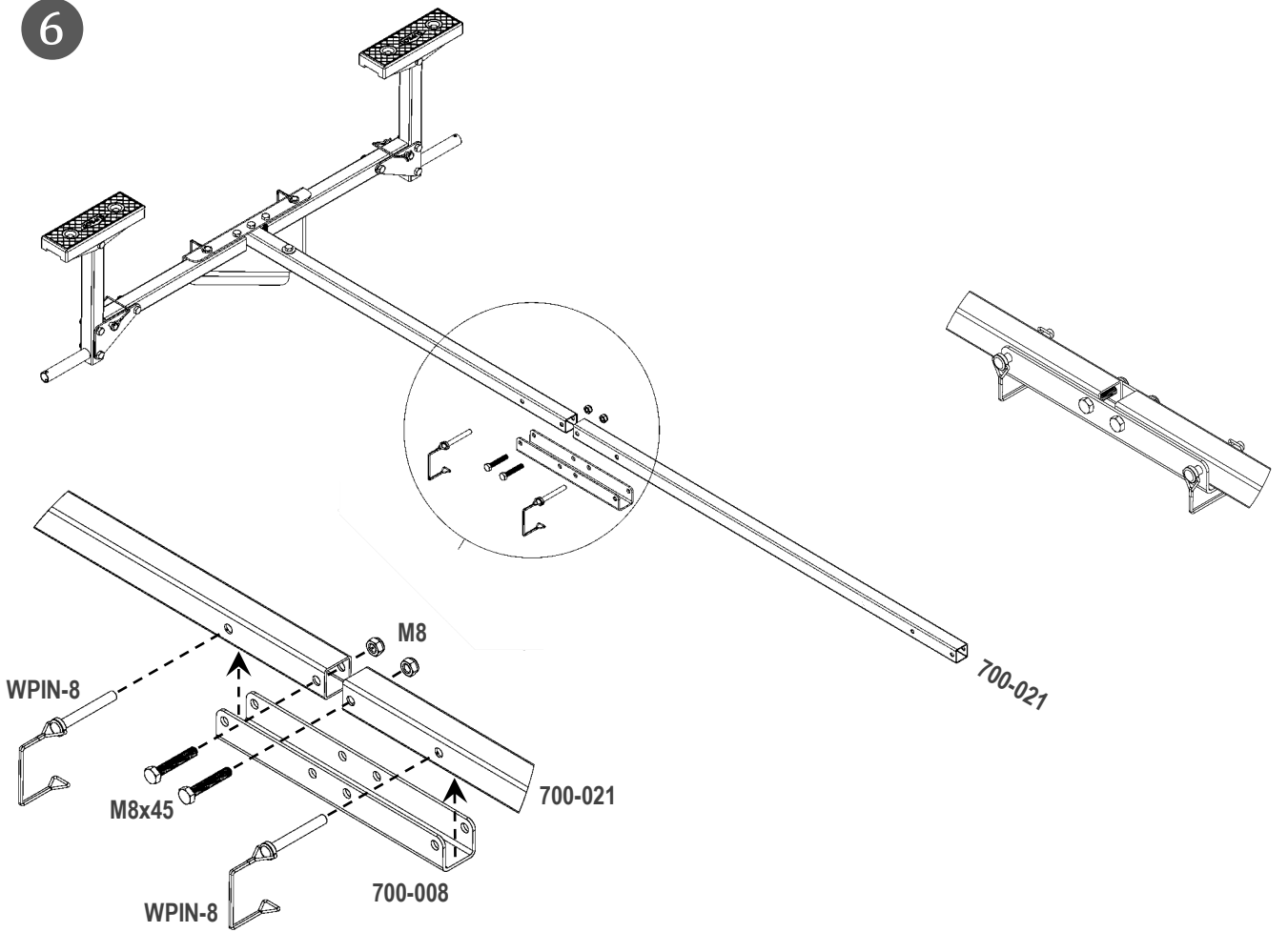

7

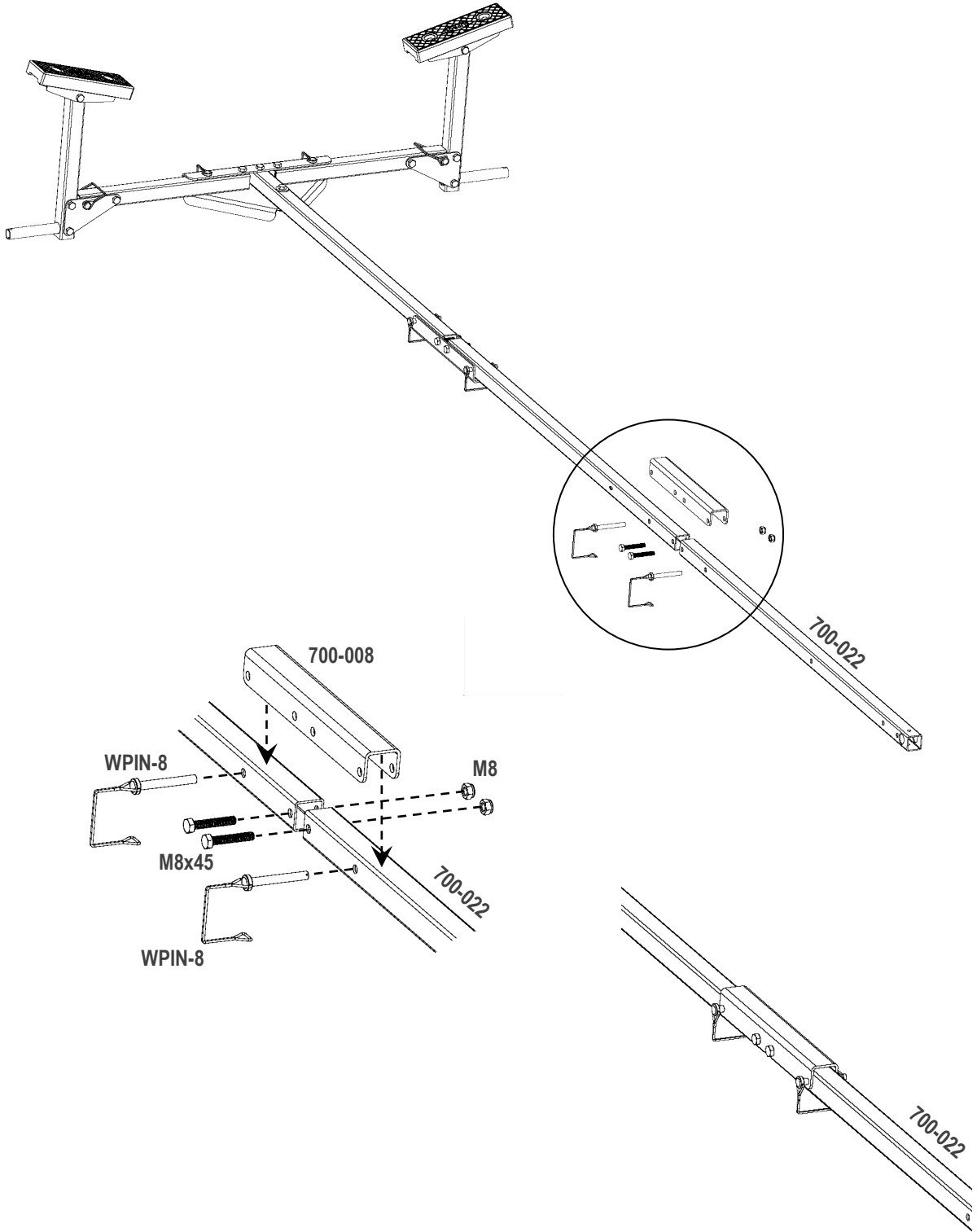

8

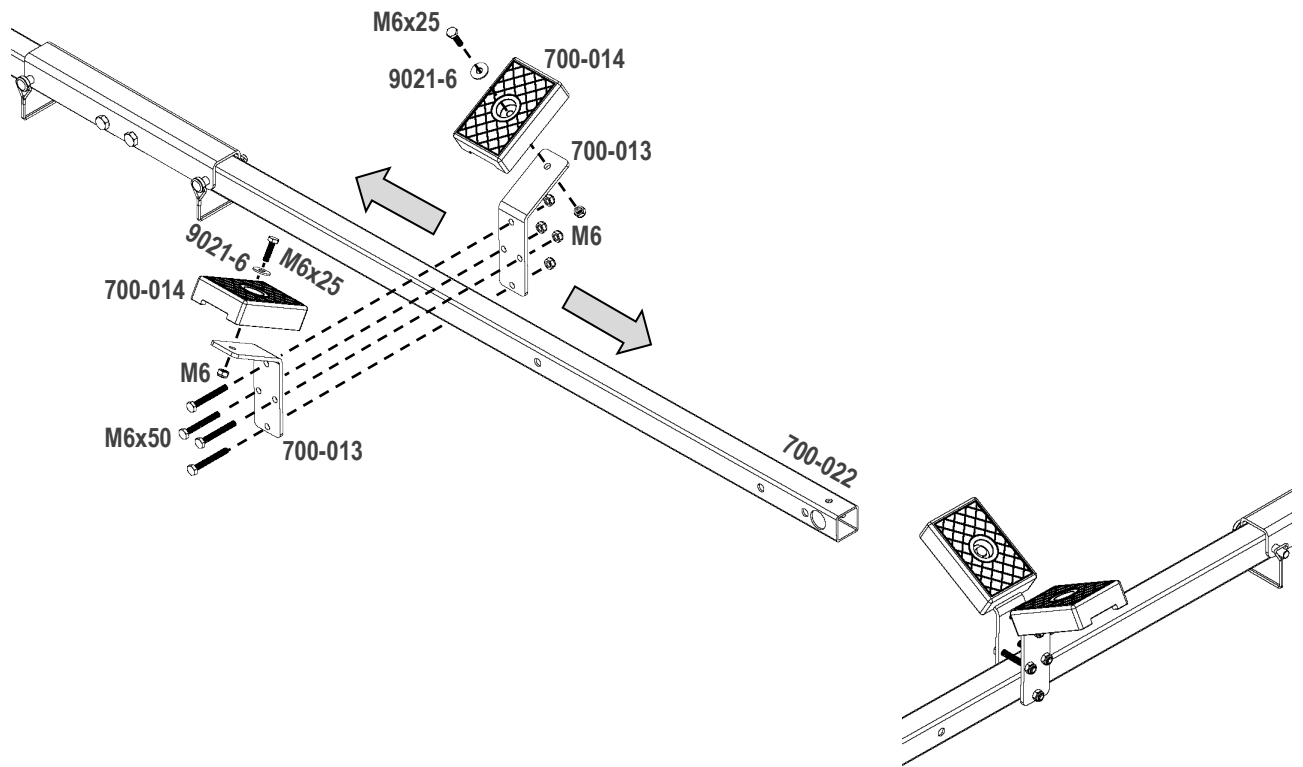

9

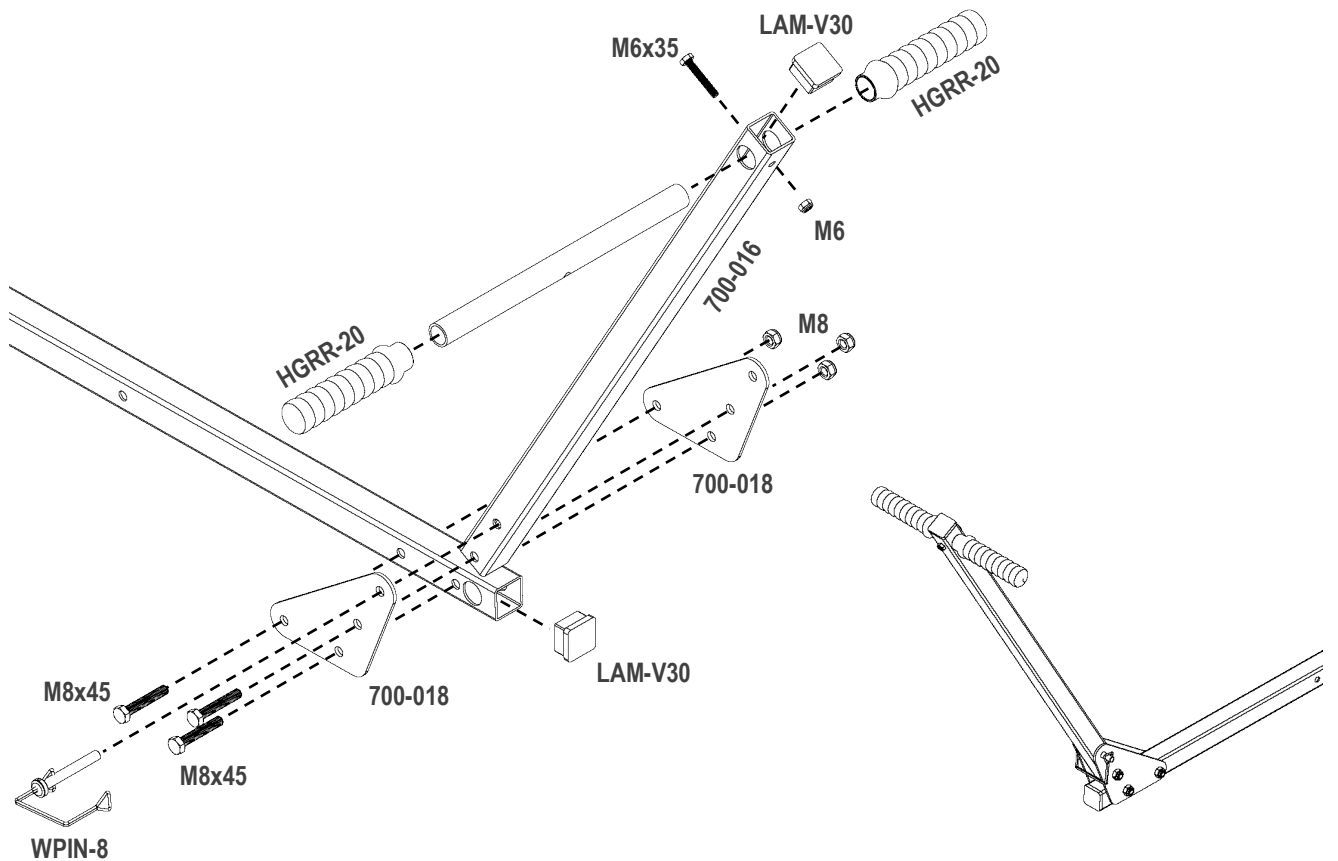

10

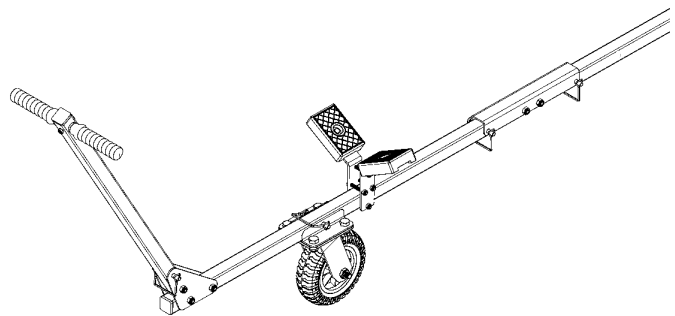
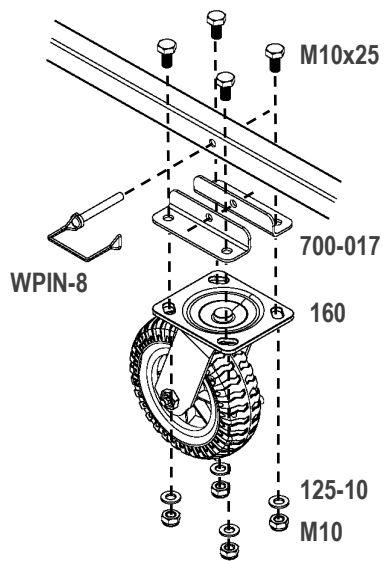

11

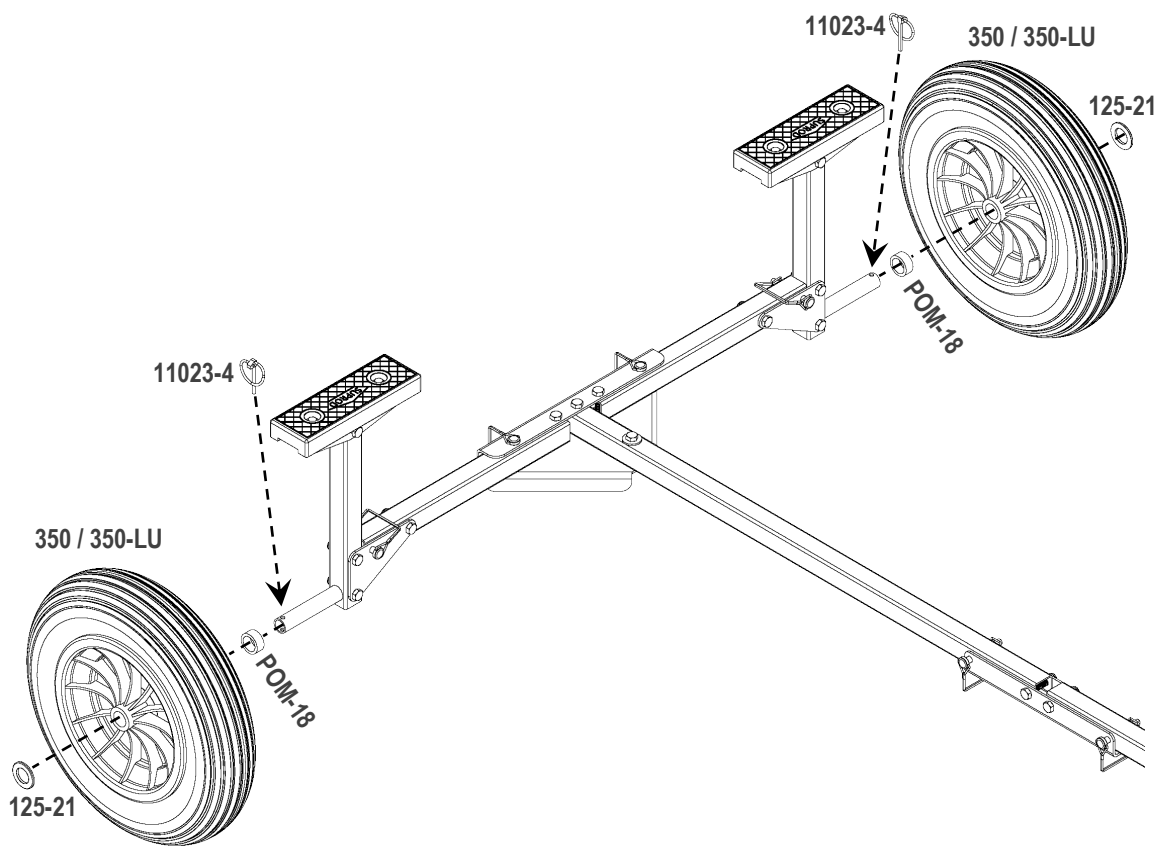

ACHTUNG

- Für Straßenverkehr nicht zugelassen.
- Für kommerzielle Anwendung nicht geeignet.
- Nicht hinter ein motorisiertes Fahrzeug anhängen.
- Personen oder Tiere dürfen beim Slippen nicht im Boot verbleiben.
- Längerer Oberflächenkontakt mit Reifen kann Abfärbungen hinterlassen.
- Gilt nur für Varianten mit Polyurethan Reifen: Hohe statische Belastung kann zur Verformung der Polyurethan Reifen führen und sollte daher vermieden werden. Die Verformung geht im entlasteten Zustand wieder zurück.
- Verwendung auf eigene Gefahr. Hersteller und Lieferanten haften nicht für Schäden oder Verletzungen, welche durch die Verwendung des Produkts verursacht wurden oder damit zusammenhängen.
- Nichtbefolgung der Hinweise, unsachgemäße Montage oder Veränderungen am Gerät führen zum Erlöschen der Gewährleistung und Garantie.

ATTENTION

- Not for highway use.
- Not designed for commercial use.
- Not designed to be towed behind a motor vehicle.
- Do not leave people or animals in the boat during transportation.
- Prolonged surface contact with the wheels may cause discoloration.
- Only applies to variants with polyurethane tires: High static load can lead to deformation of the polyurethane tires and should therefore be avoided. The deformation returns in the unloaded state back.
- The product must be used at your own discretion and risk. Manufacturer and suppliers cannot be considered liable for any direct and consequential losses, damages or injuries, caused by or related to using the product.
- Failure to follow the instructions, incorrect installations or any unauthorized modifications to the equipment will void your warranty.

